



1950
COLLECTION

79764...

Fontini

CARGADOR DOBLE USB

DOUBLE USB CHARGER

CHARGEUR DOUBLE USB

INFORMACIÓN

Función	USB tipo C + USB tipo C PD
Tensión de entrada	100-240 V.
Frecuencia	50-60 Hz.
Tensión / Intensidad de salida	5 V DC / 3 A 9 V DC / 2 A 12 V DC / 1,5 A
Modo de instalación	Empotrado s/norma UNE-EN 60.670:2006 y fijado a presión.
Norma	Construido según la normativa UNE-EN 62684:2011.
Grado de protección	IP20.

CARACTERÍSTICAS TÉCNICAS

Sección de cable admitido	2 x 2,5mm ²
Potencia absorbida sin carga	UE=230 V~ <=0,1 W.
Potencia máxima	15 W.
Tecnología de carga rápida	Power Delivery (PD)
Tipo de embornamiento	Borne con tornillo.
Temperatura ambiente de almacenamiento	-10 a 50°C.
Temperatura ambiente de funcionamiento	-45 a 400°C.

CARACTERÍSTICAS DE MATERIAL

Material soporte interior	Poliamida 66 GF15 libre de halógenos.
Color	Negra.
Material placa	Latón estampado.
Mantenimiento	Limpia con un paño suave. No utilizar limpiadores abrasivos.

DIRECTIVAS DE SEGURIDAD

Directiva 2012/19/UE de 4 de julio de 2012 (Residuos de Aparatos Eléctricos y Electrónicos (RAEE)).
Directiva 2011/65/UE de 8 de junio de 2011 (Restricción de ciertas Sustancias Peligrosas en aparatos eléctricos y electrónicos (RoHS)).
Directiva 2014/30/UE de 26 de febrero de 2014 (Directiva de Compatibilidad Electrónica)

CERTIFICADOS DE PRODUCTO

Certificado CE.

DIMENSIONES DE PRODUCTO

Medidas en mm.

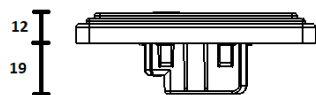

INFORMATION

Function	USB type C + USB type C PD
Input Voltage	100-240 V.
Frequency	50-60 Hz.
Output voltage / current	5 V DC / 3 A 9 V DC / 2 A 12 V DC / 1,5 A
Method of mounting	Flush-type according IEC 60670-1:2006 and fixed snapping-on.
Norm	Manufactured according: IEC 62684:2018.
Degree of protection	IP20.

TECHNICAL CHARACTERISTICS

Cross-section cable admitted	2 x 2,5mm ²
Power consumption without load	UE=230 V~ <=0,1 W.
Maximum output power	15 W.
Fast charge technology	Power Delivery (PD)
Type of terminal	Screw-type.
Ambient storage temperature	-10 a 50°C.
Ambient operating temperature	-45 a 400°C.

MATERIAL CHARACTERISTICS

Main body material	Polyamide 66 GF15 halogen free.
Colour	Black.
Plate material	Stamped brass.
Maintenance	Clean with a soft cloth. Do not use abrasive materials or cleaners.

SECURITY DIRECTIVES

Directive 2012/19/UE of 4 July 2012 (Waste on Electrical and Electronic Equipment (WEEE)).
Directive 2011/65/UE of 8 June 2011 (Restriction of Hazardous Substances in electrical and electronic equipment (RoHS)).
Directive 2014/30/UE of 26 February 2014 (Directive of Electromagnetic Compatibility).

PRODUCT CERTIFICATIONS

Certificado CE.

PRODUCT DIMENSIONS

Measures in mm.

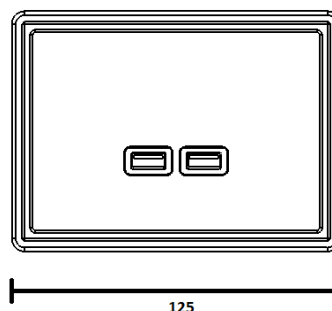
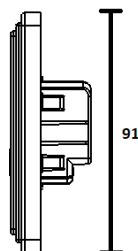

INFORMATION

Fontion	USB type C + USB type C PD
Tension d'entrée	100-240 V.
Fréquence	50-60 Hz.
Tension / Intensité de sortie	5 V DC / 3 A 9 V DC / 2 A 12 V DC / 1,5 A
Méthode de montage	Encastré suivant la norme IEC 60670-1:2006 et fixation par clip.
Norme	Fabriquée suivant la norme: CEI 62684:2018.
Indice de protection	IP20.

TECHNIQUE CARACTÉRISTIQUES

Section de câble admise	2 x 2,5mm ²
Puissance absorbée sans charge	UE=230 V~ <=0,1 W.
Puissance de sortie maximale	15 W.
Techno. de charge rapide	Power Delivery (PD)
Type de borne	Bornes à vis.
Température de stockage	-10 a 50°C.
Température de fonctionnement	-45 a 400°C.

CARACTÉRISTIQUES DES MATÉRIAUX

Matériau de la partie principale	Polyamide 66 GF15 sans halogènes.
Couleur	Noir.
Matériau de la plaque	Laiton estampé.
Entretien	Nettoyez avec un chiffon doux. Ne pas utiliser de support abrasifs.

DIRECTIVES DE SÉCURITÉ

Directive 2012/19/UE du 4 juillet 2012 (Déchets d'équipements électriques et électroniques (DEEE)).
Directive 2011/65/UE du 8 juin de 2011 (Limitation de certaines substances dangereuses dans les équipements électriques et électroniques (RoHS)).
Directive 2014/30/UE du 26 février (Directive sur la compatibilité électromagnétique).

CERTIFICATIONS DU PRODUIT

Certificado CE.

DIMENSIONS DU PRODUIT

Mesures en mm.



1950 COLLECTION

Fontini

DIMENSIONES
DE PLACA

PLATE
DIMENSIONS

DIMENSIONS
DE LA PLAQUE

91x125



91x185



91x253



91x324



CAJAS

BOX TYPES

BOÎTES



Universal
Universal
Universel
60x60x40mm



Británico
British
Britannique
75x75x35mm



Universal
Universal
Universel
Ø 65x40mm

SISTEMA
DE INSTALACIÓN

INSTALLATION
SYSTEM

SYSTÈME
D'INSTALLATION

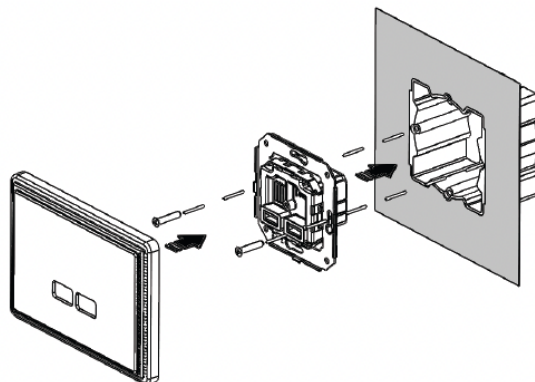

ESQUEMA DE CONEXIÓN

CONNECTION SCHEME

SCHEMA DE CONNEXION

